

# UCG 230 - 12

## 12V 230AH

### DEEP CYCLE AGM GEL COMBINATION

# Ultracell®

'Quality in Every Language'

Image



Terminal Type

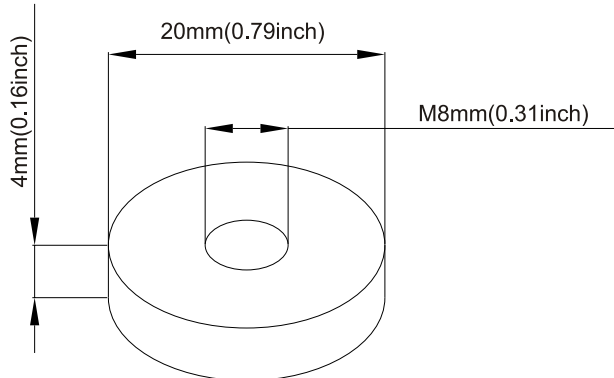

Dimensions

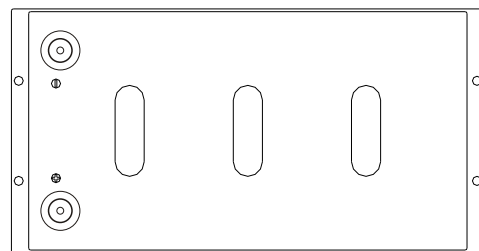
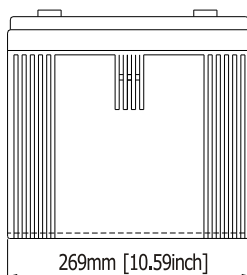
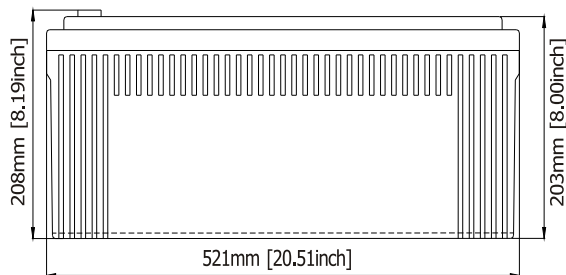

Specifications

Battery Model	UCG 230 - 12			
Designed Floating Life	15 Years			
Capacity (25°C)	20HR (12.0A, 1.75V)	10HR (23A, 1.75V)	5HR (40A, 1.75V)	1HR (140A, 1.75V)
	240AH	230AH	200AH	140AH
Dimensions	Length	Width	Height	Total Height
	521mm	269mm	203mm	208mm
Approx. Weight	67.0Kg			
Internal Resistance	Fully Charged at 25°C 0.003 Ohm			
Self Discharge	3% of capacity declined per month at 25°C			
Capacity Affected by Temperature	40°C	25°C	0°C	-15°C
	102%	100%	85%	65%
Charge Voltage (25°C)	Cycle Use		Float Use	
	14.4-15V (-30mV/C), max. Current: 57.5A		13.6-13.8V (-20mV/C)	

Construction

Component ——— Raw material  
 Positive ——— Lead dioxide  
 Negative ——— Lead  
 Container ——— ABS (Flame Retardent optional)  
 Cover ——— ABS (Flame Retardent optional)

*Sealed and maintenance free option*

Sealant ——— Epoxy Resin  
 Safety Valve ——— EPDR  
 Terminal ——— Copper  
 Separator ——— Fibre Glass  
 Electrolyte ——— Sulphuric acid and Gel

*Non-spillable construction design*



Tel | +44 (0) 151 523 2777  
 Fax | +44 (0) 151 523 0855  
 E-mail | info@ultracell.co.uk  
 Web | www.ultracell.co.uk

Charge Characteristic

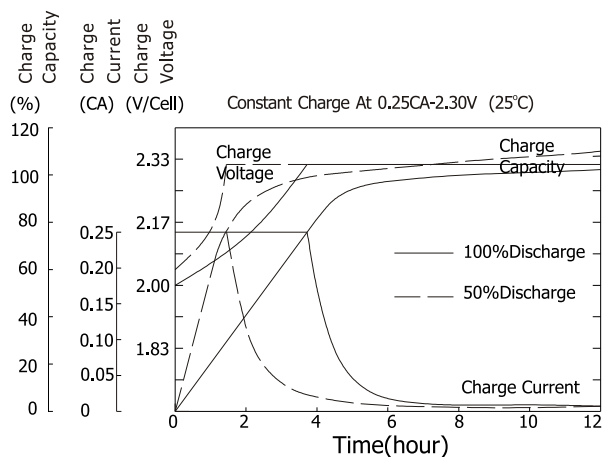

Discharge Characteristic 25°C

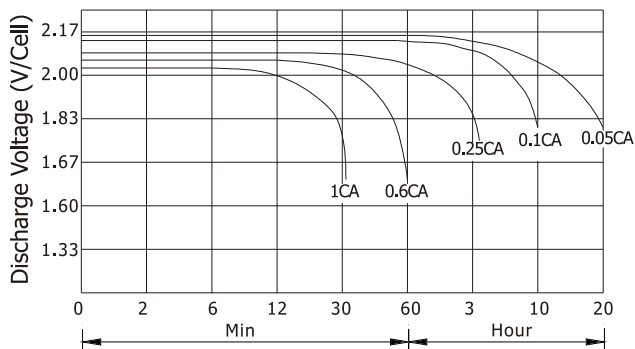

Relationship of OCV and state of charge

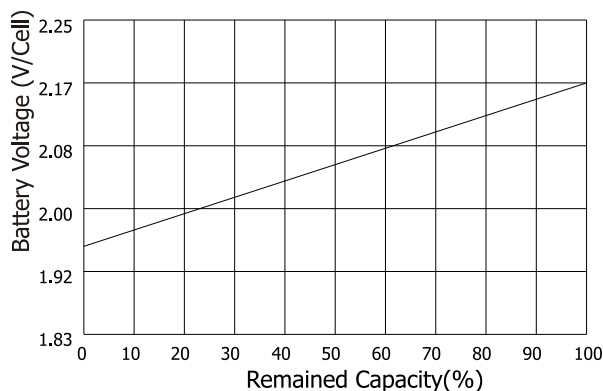

Life Expectancy Cycle Use:

- 100% depth of discharge 350 cycles
- 80% depth of discharge 600 cycles
- 50% depth of discharge 900 cycles
- 30% depth of discharge 1500 cycles
- 20% depth of discharge 1700 cycles

Constant Current Discharge Ratings - amperes at 25°C

F.V / Time	5 MIN	10 MIN	15 MIN	30 MIN	1 HR	3 HR	5 HR	10 HR	20 HR
1.60 V	788	540	394	236	144	59.5	41.6	24.4	12.1
1.67 V	709	493	383	230	144	59.3	41.3	24.0	12.1
1.70 V	673	475	369	225	143	59.3	41.3	23.8	12.1
1.75 V	599	439	349	221	142	58.9	40.9	23.4	12.0
1.80 V	540	407	333	214	140	58.6	40.6	23.0	11.6
1.85 V	410	335	288	197	138	58.4	40.2	22.6	10.9

Constant Power Discharge Ratings - watts at 25°C

F.V / Time	5 MIN	10 MIN	15 MIN	30 MIN	1 HR	3 HR	5 HR	10 HR	20 HR
1.60 V	1292	892	694	444	285	115	79.9	48.8	24.2
1.67 V	1225	880	688	435	275	115	79.9	48.0	24.2
1.70 V	1145	858	676	423	268	115	79.9	47.7	24.2
1.75 V	1066	802	636	412	266	113	79.1	46.9	24.0
1.80 V	956	746	598	401	261	111	77.7	46.0	23.2
1.85 V	766	618	522	367	259	111	76.7	45.2	21.8



**Tel** | +44 (0) 151 523 2777  
**Fax** | +44 (0) 151 523 0855  
**E-mail** | info@ultracell.co.uk  
**Web** | www.ultracell.co.uk